

GE INDUSTRIAL PUMPS

A Division of Glauber Equipment Corporation

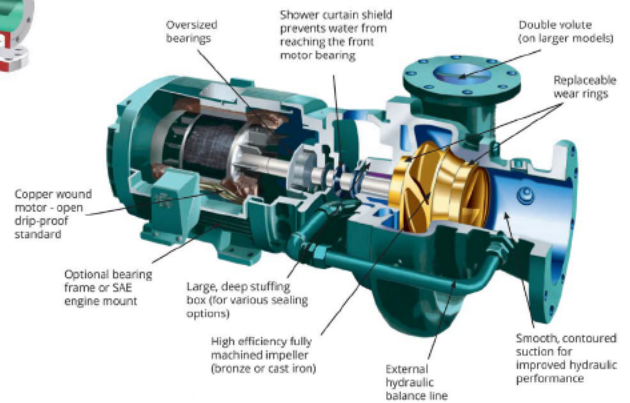
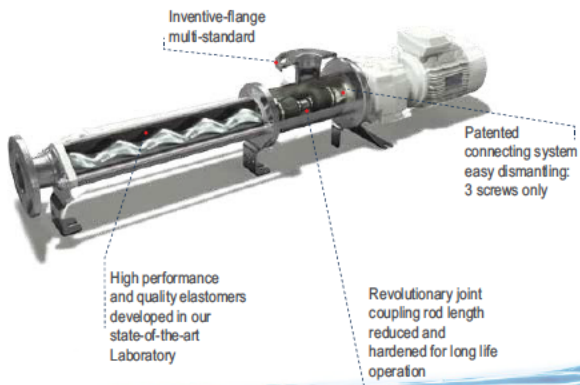
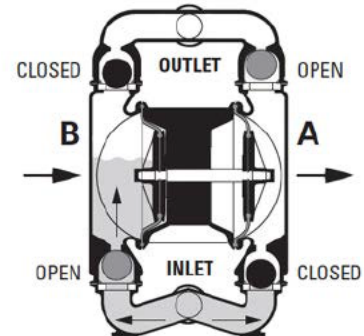
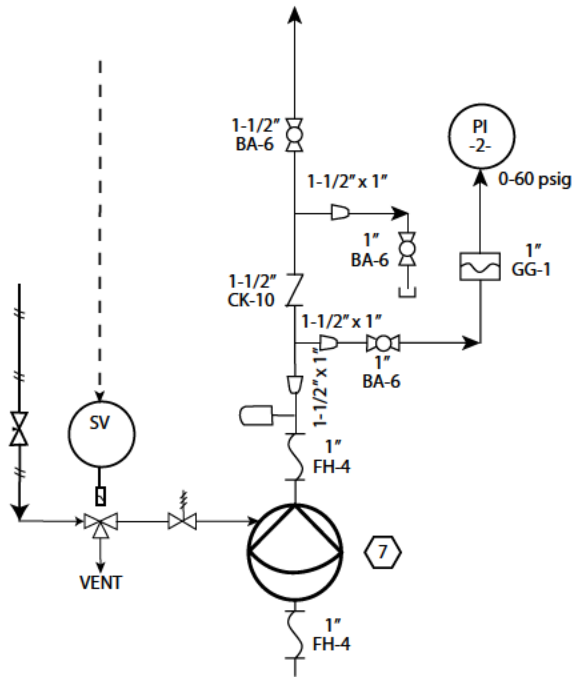

Pump Solutions For A Diverse Marketplace

Pumps • Skids • Systems • Heat Exchangers • Blowers

For More Information Call: 1-888-GLAUBER



Agricultural



Crops, Animal Production, Fisheries, Forestry

- Vertical Sump Pumps
- Horizontal End Suction
- Rotary Lobe



Applications

- Clear Liquid
- Manure
- Food Process
- Cutter
- Self Priming



Construction / Mining



Buildings, Quarry, Drilling, Paving, Bridges, Aggregate, Excavation, Sand, Gravel, Demolition, Highway

- Centrifugal-Vertical/Horizontal
- AOD-Air Operated Diaphragm
- Submersible
- Self Priming
- Peristaltic



Applications

- Dewatering
- Wastewater
- Slurry Handling
- High Suction Lift
- Solids and Abrasives
- Run Dry



Chemical



Refining

- Drum & Container Pumps
- AOD-Air Operated Diaphragm
- Eccentric Disc
- Centrifugal-Vertical/Horizontal
- Metering
- Peristaltic
- Progressive Cavity
- Internal & External Gear Pumps
- Non-Metallic



Applications

- Paints, Coatings & Inks
- Resins, Adhesives
- Soap and Detergents
- Acids, Corrosives, Caustics
- Plating, Finishing



Food & Beverage



Dairy, Bottling, Packing, Filling, Packaging, Bake

- AOD-Air Operated Diaphragm
- Rotary Lobe
- Drum & Container Pumps
- Progressive Cavity
- Eccentric Disc
- Stamped Stainless Centrifugal
- Metering



**Offering Sales,
Inventory
& Service
Across
New York State!**





Industrial Plant Process



Machining, Moulding, Forming, Packaging, Processing, Plastics, Stamping, Plating, Coating, Fabricating, Textile, Recycling



- Drum & Container Pumps
- AOD- Air Operated Diaphragm
- Internal & External Gear Pumps
- Centrifugal-Vertical/Horizontal
- Plunger
- Blowers



Applications

- Hot Oil
- Refrigeration
- Solids Handling
- Submersible
- Coolants, Lubricants



ry, Confectioners, Meat, Seafood, Poultry, Ingredients

Applications

- Hygienic Approved
- Sauce, Syrup Transfer
- Additives and Ingredients
- Whole Food Transport
- Dosing, Mixing, Filling
- Waste Handling
- Refining
- (Clean in Place) CIP, (Steam in Place) SIP

Medical / Pharmaceutical



Hospitals, Medicines, Research, Testing



- Regenerative Turbine
- Drum & Container Pumps
- Progressive Cavity
- Eccentric Disc
- AOD-Air Operated Diaphragm
- Centrifugal-Vertical/Horizontal
- Non-Metallic



Applications

- Handling of Ingredients, Cosmetics, and Live Cultures
- Wastewater
- Sterile
- Refrigeration
- (Clean in Place) CIP, (Steam in Place) SIP
- Blending, Recovery, Separation



Oil & Gas



Refining, Exploration, Drilling



- AOD-Air Operated Diaphragm
- Centrifugal-Vertical/Horizontal
- Internal & External Gear Pumps
- API 610 Compliant
- Submersible



Applications

- DAF (Dissolved Air Flotation)
- Dry Prime Pumps
- Solids Handling
- Lube, Crude Oil Transfer
- Waste Transfer



Power Generation



Nuclear, Hydroelectric, Energy, Coal

- Centrifugal-Vertical/Horizontal
- Internal & External Gear Pumps



Applications

- Drainage
- Lube Oil
- Water Treatment
- Cooling, Circulation
- Condensate
- Boiler Feed



Printing



Offset, Flexographic, Platemaking, Varnish & UV Coating

- AOD-Air Operated Diaphragm
- Peristaltic
- Internal & External Gear Pumps



Applications

- Ink Transfer
- Developer Transfer



Pulp and Paper



Paperboard, Sawmills, Papermills, Tissue, Fibre, Containerboard, Corrugated, Converting

- Rotary Lobe
- Drum & Container Pumps
- Plunger
- Centrifugal-Vertical/Horizontal
- Progressive Cavity
- Metering



Applications

- Solids Handling
- High Pressure Water
- Chemical Dosing
- Liquid Transfer
- Wastewater/Sewage
- Paper Finishing
- Stock Preparation
- Bleaching



GE INDUSTRIAL PUMPS

A Division of Glauber Equipment Corporation



Recreation



Theme Parks, Water Parks, Golf Courses, Amusement Parks, Zoos, Aquariums



- Rotary Lobe
- Drum & Container Pumps
- AOD-Air Operated Diaphragm
- Centrifugal-Vertical/Horizontal
- Non-Metallic
- Stainless Steel

Applications

- Wastewater/Sewage
- Drainage
- High Pressure Water
- Liquid Transfer
- Irrigation
- Pool/Pond Circulation



Wastewater Treatment



Sewage, Effluent, Aerobic Treatment, Greywater, Municipal, Aeration, Sludge



- AOD-Air Operated Diaphragm
- Rotary Lobe
- Metering
- Submersible
- Split Case
- Vertical Multistage



Applications

- Dewatering
- Solids Handling
- Grinders
- Effluent
- Chemical Dosing



Pump Type / Manufacturer

- Air Operated Diaphragm (AOD)**
Almatec, Wilden
- ANSI Pumps**
Barmesa, Crane, Dickow, Fybroc, Griswold
- API Pumps**
Carver, Dickow, National Pump
- Centrifugal - Horizontal End Suction**
Barmesa, Barnes, Burks, Carver, Deming, Dickow, Flux/Renner, Fybroc, Griswold, MTH, Vertiflo, Weinman
- Centrifugal - Vertical**
Barnes, Carver, Cornell, Crane, Deming, Fybroc, Vertiflo, Weinman
- Drum & Container**
Flux, Wilden
- Eccentric Disc**
Mouvex
- Food Handling**
Almatec, Cornell, Envirogear, Flux/Renner, PCM-Moineau, Maag G, Mouvex, Verder/Alfa Laval SSP, Vogelsang, Wilden
- Gear Pumps**
Envirogear, Maag G
- Grinder/Chopper/Cutter Pumps**
Barmesa, Barnes, Cornell, Vogelsang
- High Pressure Plunger**
General Pump
- Hygienic/Sanitary**
Almatec, Mouvex, Verder/Alfa Laval SSP, Wilden
- Inline Pumps**
Barmesa, Weinman
- Mag-Drive**
Dickow, Envirogear, Flux/Renner, Fybroc, MTH
- Metering Pumps**
Mouvex, Neptune, Stenner, Verder/Alfa Laval SSP
- Non-Clog/Solids Handling**
Barmesa, Barnes, Cornell, Deming, Vogelsang
- Non-Metallic**
Flux/Renner, Fybroc
- Peristaltic - Hose Pumps**
Abaque, Stenner
- Progressive Cavity**
Flux, PCM-Moineau
- Regenerative Turbine**
Burks, MTH
- Rotary Lobe**
Verder/Alfa Laval SSP, Vogelsang
- Screw Channel**
Verderhus
- Sealless Pumps**
Dickow, Envirogear, Flux / Renner, Fybroc, Mouvex, MTH
- Self Priming**
Barmesa, Barnes, Burks, Cornell, Crown
- Side Channel**
Dickow
- Split Case**
Deming, Weinman
- Stainless Steel**
Almatec, Barmesa, Carver, Envirogear, Griswold, Maag G, Mouvex, MTH, PCM-Moineau, Verder/Alfa Laval SSP, Vertiflo, Vogelsang, Wilden
- Submersibles**
Barmesa, Barnes, Cornell, Prosser
- Sump Pump**
Barmesa, Carver, Deming, Weinman
- Trash Pump**
Barmesa, Cornell, Crane
- Vertical Multistage**
Barmesa, Burkes, Carver
- Vertical Turbine**
Fybroc, National Pump

Certifications & Compliance



- EN 10204 2.1 and 3.1 certification and material traceability
- EHEDG accredited highest level of cleanability
- ATEX Directive 94/9/EC, Group II, Categories 2 and 3
- CIP/SIP
- USA 3-A
- FDA CFR 21.177
- USP Class VI
- 1935/2004/EC

Aftermarket Parts and Service

Glauber Equipment repairs and completely rebuilds most brands of commercially available pumps. Additionally we are factory certified on all products we carry. On-site service and trouble shooting is available 24/7.
Call 888-GLAUBER (888-452-8237) to schedule service.

Accessories

Got Gauges? Got Filtration? Got Valves?

- We Do!



Let us quote you on a new valve, gauge or filter along with your pump.

We now offer:

- Butterfly, Ball, Gate, Globe, Check, Needle and Relief Valves.
- Pressure and Temperature Gauges, Switches and Sensors
- Liquid, Sanitary Filter Housings and Vessels. Replacement Cartridges and Bag Elements.
- Plate and Frame Heat Exchangers



GE GLAUBER
EQUIPMENT CORPORATION

INDUSTRIAL AIR INDUSTRIAL PUMPS INDUSTRIAL VALVES, GAUGES & FILTERS GLAUBER PUMPS

Divisions of Glauber Equipment Corporation

Corporate Headquarters: 1600 Commerce Parkway
Lancaster, New York 14086