

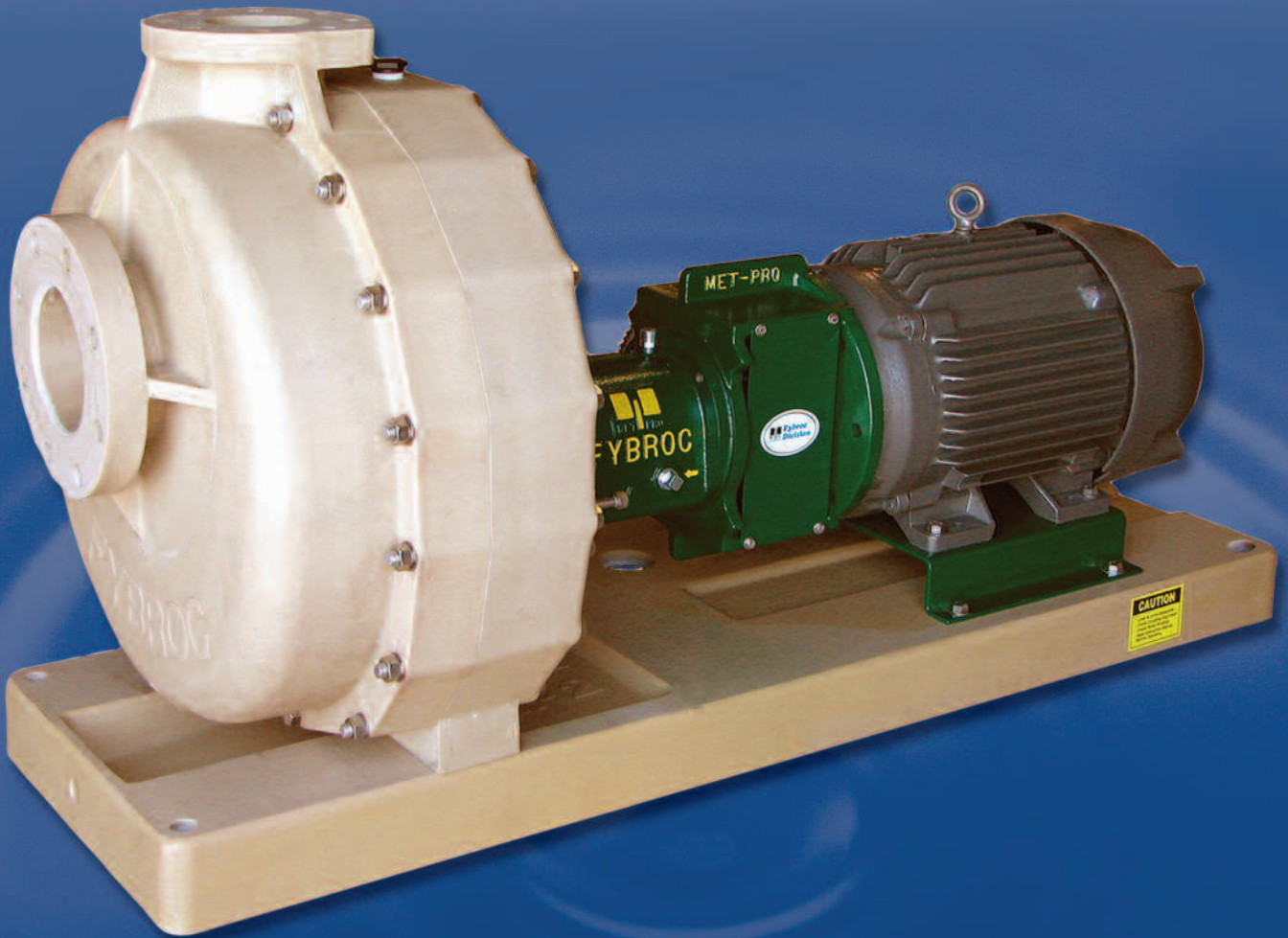

**Fybroc Division**

**SERIES 1600**



# Self-Priming Fiberglass Pumps

BULLETIN 16B1

# FYBROC – THE LEADER IN CORROSION-RESISTANT FIBERGLASS PUMPING EQUIPMENT

Fybroc is the leading manufacturer of fiberglass reinforced centrifugal pumps designed specifically to handle difficult corrosive liquids. The Fybroc Series 1600 combines an extensive knowledge of materials

and production techniques to provide exceptional structural integrity and excellent corrosion-resistance in a high quality self-priming pump.

## FYBROC SERIES 1600 SELF-PRIMING PUMPS

The Series 1600 pump line has been designed for maximum versatility and is ideally suited for corrosive waste sump applications, tank car unloading and other demanding services. The casing has been designed with generous proportions in the recirculation chamber to provide short priming times without the use of troublesome flappers and check valves. The inlet has been sized to minimize NPSH requirements to provide greater allowable suction lifts. The pump's flexible

stuffing box design accepts a wide variety of shaft sealing configurations to suit the needs of specific applications, including both outside and double inside mechanical seals. For additional corrosion-resistance, the entire pump and drive unit is mounted on a Fybroc fiberglass baseplate. When weight and space needs are critical, the pump is also available in a close-coupled configuration as a Series 1630.

## INTERCHANGEABILITY WITH FYBROC SERIES 1500 PUMPS

The Fybroc Series 1600 self-priming pump is, with the exception of its two piece casing, totally interchangeable with the Series 1500 ANSI pump. The bearing housing assembly, bearings, shaft, impeller, back cover, gland and mechanical seal are the same as Fybroc's reliable Series 1500 pump, ensuring maximum parts availability and interchangeability.

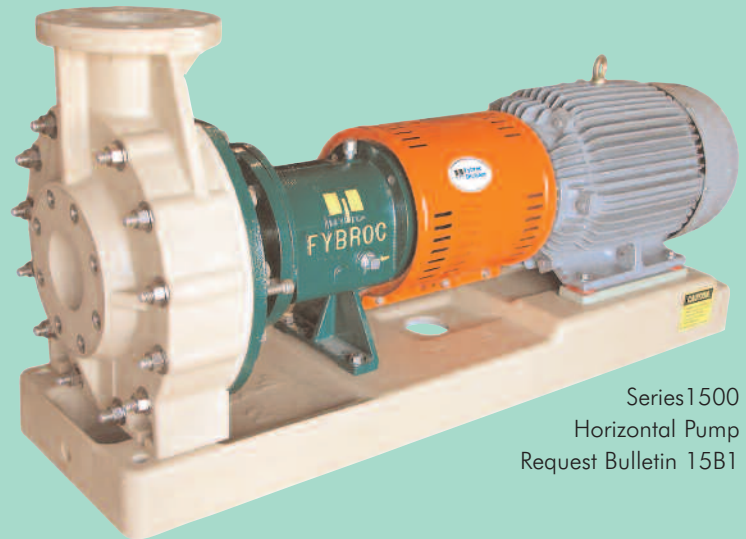

Series 1500  
Horizontal Pump  
Request Bulletin 15B1

## METHOD OF PRIMING

The Fybroc Series 1600 is designed to provide superior priming characteristics. In many cases, the Series 1600 primes in as little as half the time of the other self-primers. To achieve priming, liquid from an external source is initially introduced into the empty pump through the fill plug, filling the casing to the suction flange. When the pump is started, the impeller discharges a mixture of liquid and entrained air into the discharge chamber, where the air is separated and vented through the discharge while the heavier liquid is returned to the impeller through the inlet port at the bottom of the volute. The priming liquid entrains more air in the suction chamber and the cycle continues until the suction line is evacuated, at which time the pump is “primed.”

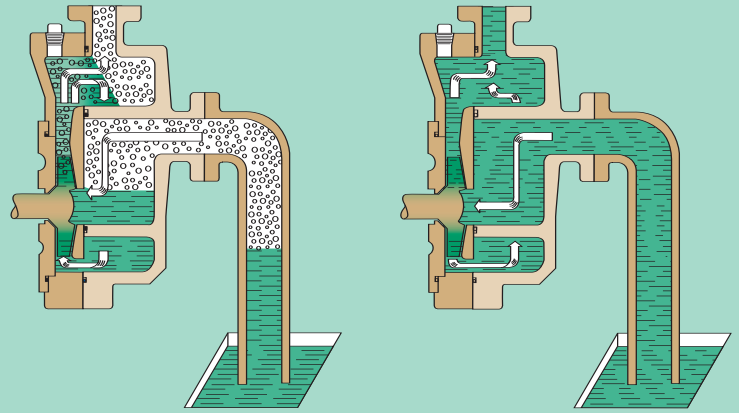

## MATERIALS OF CONSTRUCTION

The Series 1600 is furnished with all wetted components made of fiberglass-reinforced vinyl ester resin, which offers broad corrosion resistance to most acids, caustics, bleaches, seawater and many other liquids. The pumps are built with type 303 stainless steel shafts and hardware, Viton O-rings, and polyester thermosetting powder coated cast iron bearing frame components.

Corrosion-resistant, fiberglass reinforced vinyl ester resin baseplates are also available for all Series 1600 pumps. Each baseplate incorporates a sloping catch basin, eliminating expensive alloy drip pans or rim baseplates. All baseplates are predrilled to accept standard NEMA frame motors. Optional stilt-mounted baseplates are also available. Please refer to Fybroc’s Chemical Resistance Guide, Bulletin MS-101, for information on corrosion resistance to specific chemicals.

## VOLUTE EXTENSION

An important feature of the Series 1600 is its replaceable volute extension. The casing volute cutwater in any self-priming pump must be in close proximity to the impeller in order to permit efficient priming. The removable volute extension in the Series 1600 unit is available in a number of sizes to match specific impeller diameters permitting field hydraulic changes without casing modifications. The volute extension is bolted into the casing through the use of fiberglass hardware and sealed with a Viton O-ring.

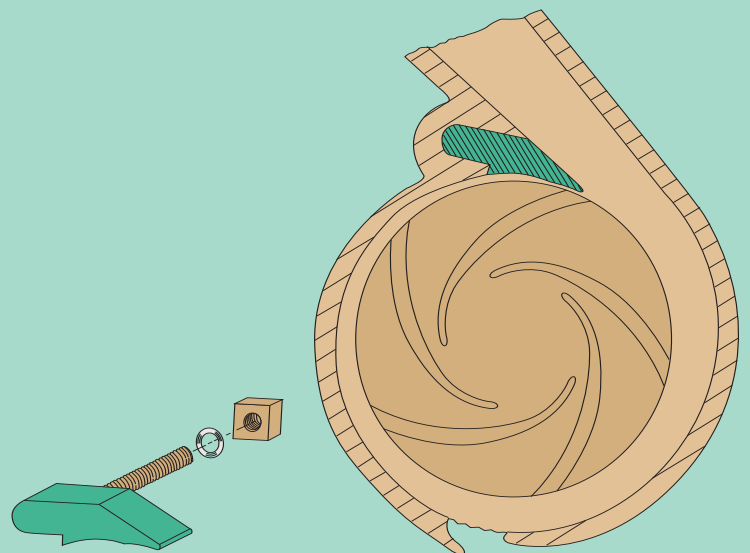

# DESIGN FEATURES OF THE SERIES 1600 PUMP

The Fybroc Series 1600 fiberglass pump is designed to handle the demands of corrosive waste sump transfer, tank car unloading and other difficult self-priming applications. Advanced molding techniques provide high strength fiberglass components for trouble-free operation.

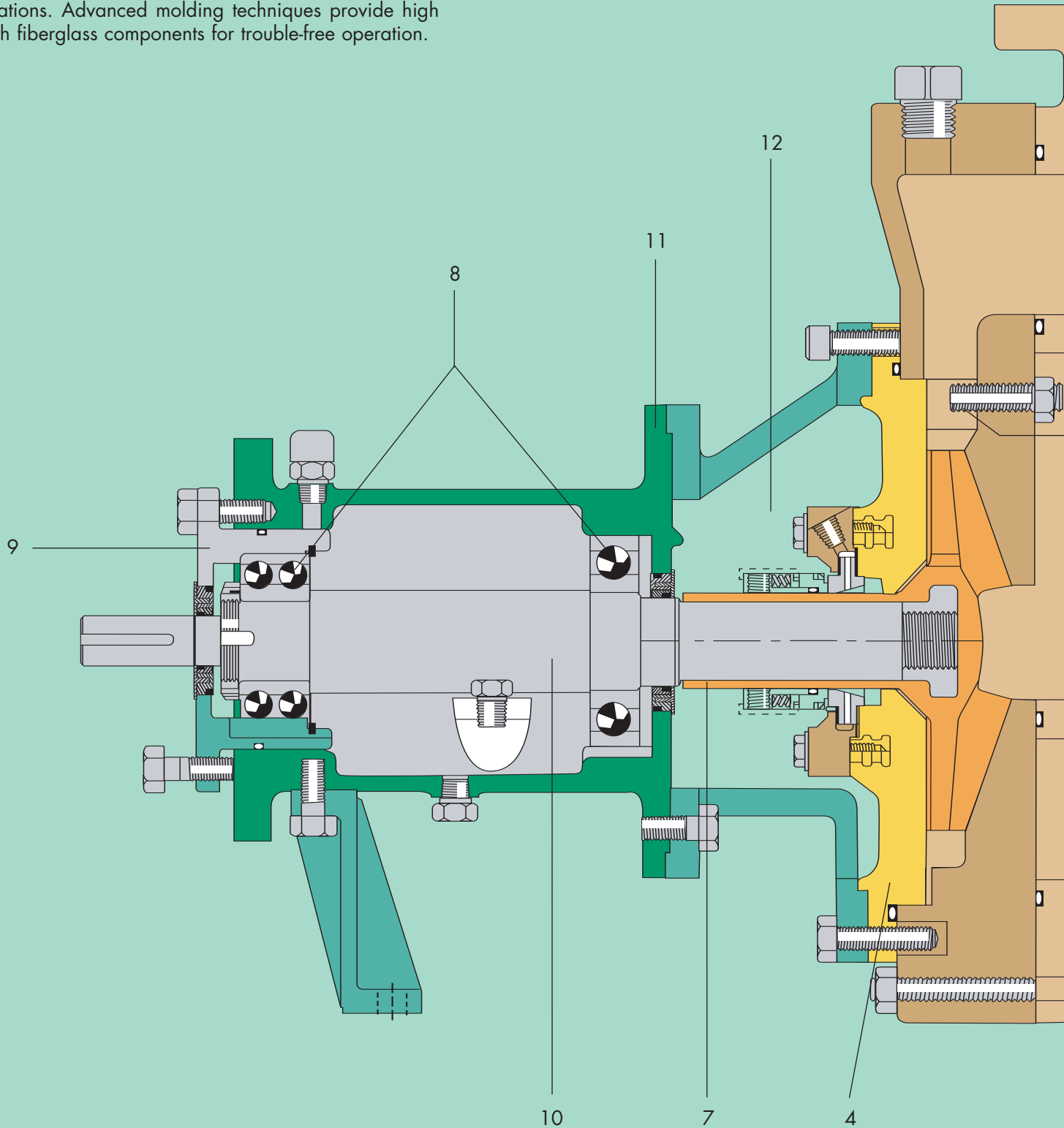

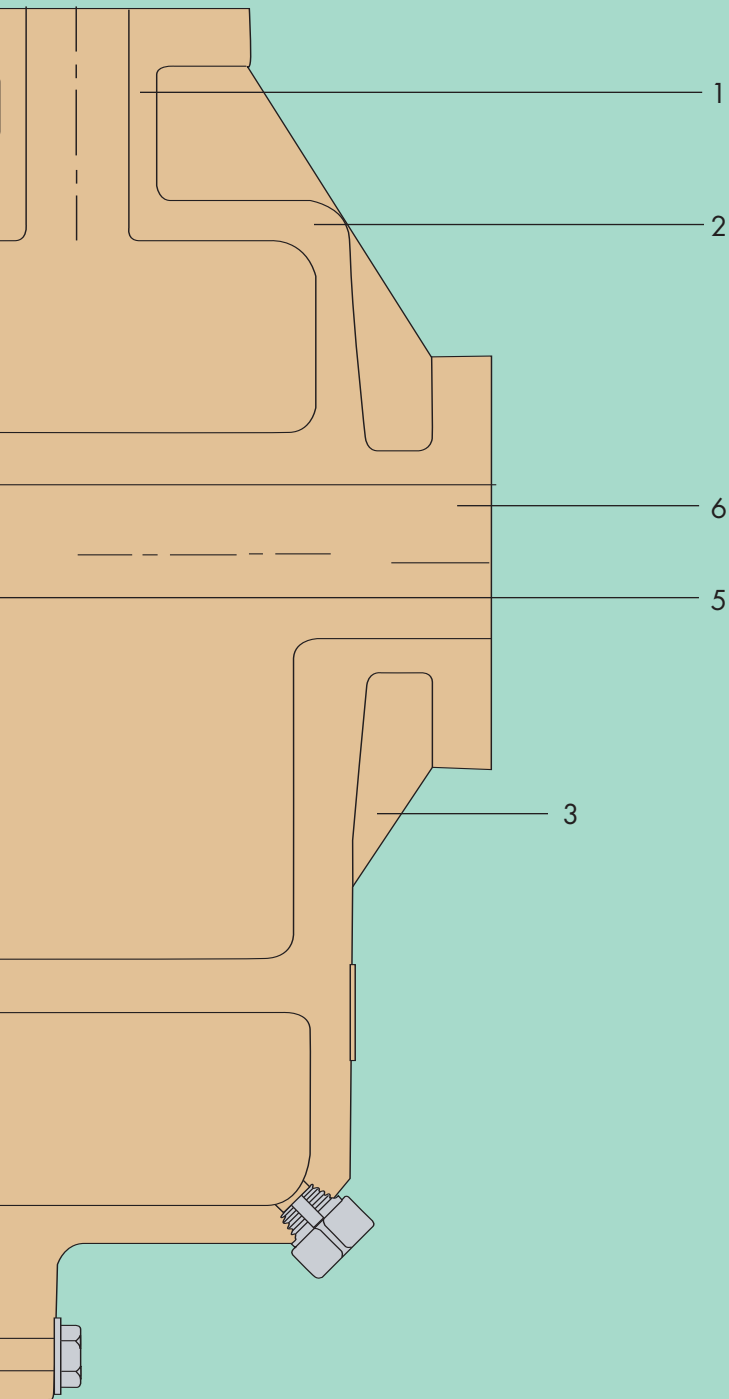

1. **FIBERGLASS CONSTRUCTION** of all wetted parts in vinyl ester resin provides tough corrosion-resistance for a wide range of difficult liquids.
2. **SELF-PRIMING CASING** with generous hydraulic passages affords excellent priming performance without the use of check valves.
3. **GUSSETED FLANGES** are integrally molded with the casing to easily support plant piping loads.
4. **VERSATILE CASING COVER** permits the use of the most popular outside and double inside mechanical seals or packing to suit specific applications.
5. **REPLACEABLE VOLUTE EXTENSION** restores priming efficiency and permits simple hydraulic changes in the field.
6. **INLET SIZED TO MINIMIZE NPSH** requirements, increasing the maximum available lift.
7. **INTEGRAL SHAFT SLEEVE** design eliminates gaskets and O-rings. Optional, separate fiberglass or metal shaft sleeves are also available.
8. **LARGE CAPACITY BEARINGS** ensure extended operating life in excess of the minimum specified by ANSI B73.1.
9. **EXTERNAL IMPELLER ADJUSTMENT** allows field setting of impeller to casing clearance.
10. **HEAVY-DUTY SHAFT** minimizes deflection to maximize mechanical seal life.
11. **POLYESTER THERMOSETTING POWDER COATED POWER FRAME** components prevent external corrosion.
12. **INTERCHANGEABILITY WITH FybROC SERIES 1500 ANSI PUMP** simplifies parts and maintenance requirements. Refer to FybROC Bulletin 15B1 for a complete description of this product line.

# SERIES 1600 HYDRAULIC COVERAGE

## 60 HERTZ

1150 RPM, 1750 RPM, 3500 RPM

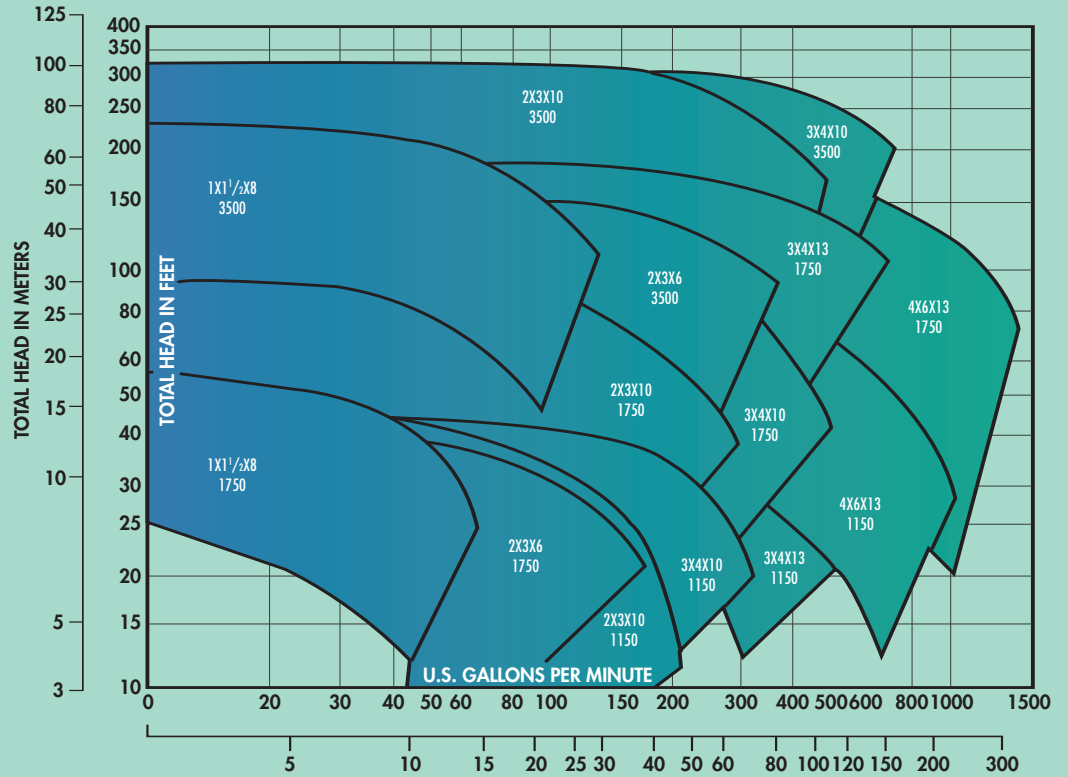

## 50 HERTZ

950 RPM, 1450 RPM, 2900 RPM

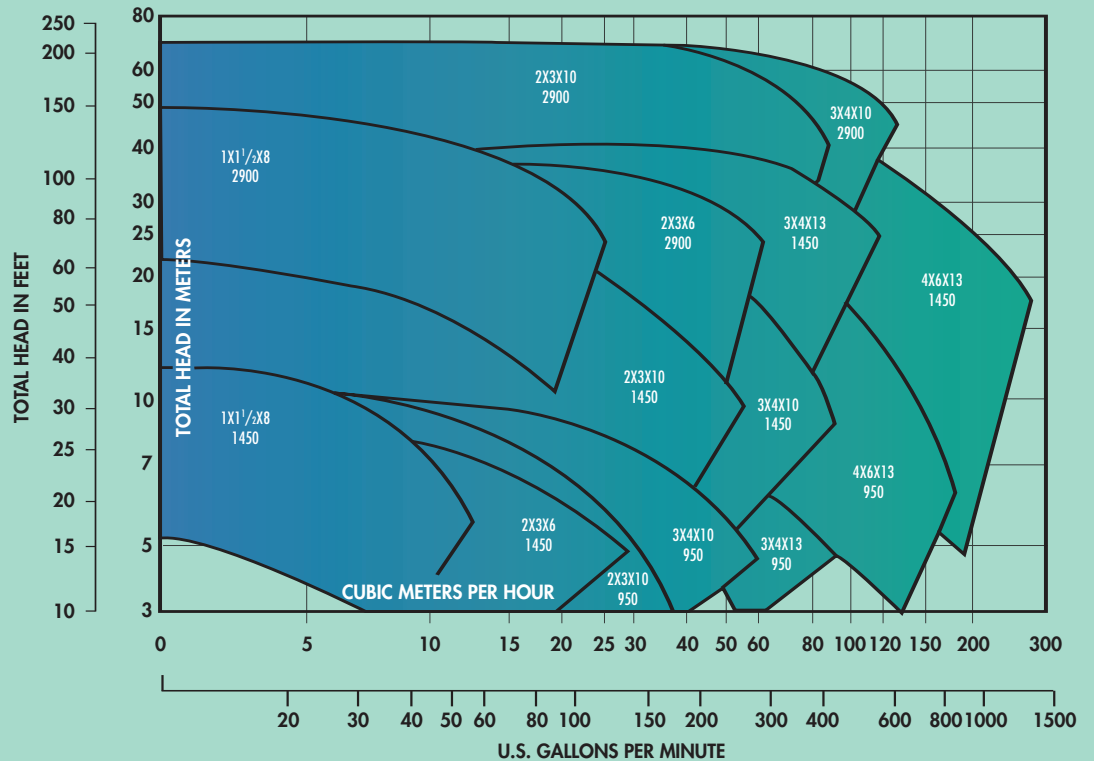

# PUMP DIMENSIONS FOR SERIES 1600

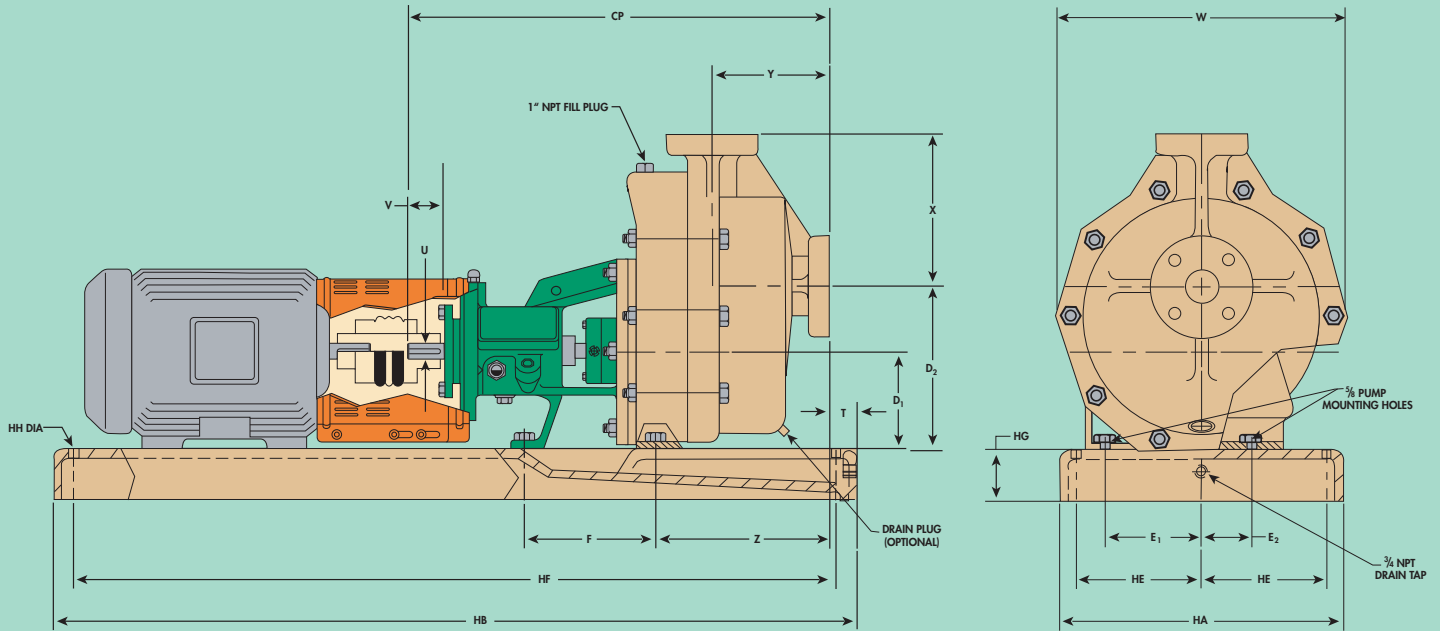

SIZE	SUCTION	DISCHARGE	CP	D <sub>1</sub>	D <sub>2</sub>	2E <sub>1</sub>	2E <sub>2</sub>	F	T	U	KEYWAY	V	W	X	Y	Z	MOTOR FRAME	BASEPLATE
2 X 3 X 6	3 (76.2)	2 (50.8)	23 <sup>3</sup> / <sub>4</sub> (603.25)	5 <sup>1</sup> / <sub>4</sub> (133.35)	9 <sup>1</sup> / <sub>8</sub> (231.77)	11 (279.4)	0 (0)	7 <sup>1</sup> / <sub>4</sub> (184.15)	0 (0)	7/8 (22.22)	3/16 X 3/32 (12.7 X 2.38)	2 (50.8)	17 <sup>5</sup> / <sub>8</sub> (447.67)	9 <sup>1</sup> / <sub>8</sub> (231.77)	7 (177.8)	10 <sup>1</sup> / <sub>4</sub> (260.35)	143T-256T	SP-1
1 X 1 <sup>1</sup> / <sub>2</sub> X 8	1 <sup>1</sup> / <sub>2</sub> (38.1)	1 (25.4)	21 <sup>5</sup> / <sub>8</sub> (549.27)	5 <sup>1</sup> / <sub>4</sub> (133.35)	8 <sup>7</sup> / <sub>8</sub> (225.42)	11 (279.4)	0 (0)	7 <sup>1</sup> / <sub>4</sub> (184.15)	2 <sup>1</sup> / <sub>8</sub> (53.97)	7/8 (22.22)	3/16 X 3/32 (12.7 X 2.38)	2 (50.8)	14 <sup>3</sup> / <sub>8</sub> (365.12)	7 (177.8)	6 (152.4)	8 <sup>1</sup> / <sub>8</sub> (206.37)	143T-256T	SP-1
2 X 3 X 10	3 (76.2)	2 (50.8)	31 <sup>3</sup> / <sub>4</sub> (803.27)	8 <sup>1</sup> / <sub>4</sub> (209.55)	14 <sup>1</sup> / <sub>4</sub> (361.95)	12 (304.8)	7 <sup>1</sup> / <sub>4</sub> (184.15)	12 <sup>1</sup> / <sub>2</sub> (317.5)	2 <sup>1</sup> / <sub>4</sub> (57.15)	1 <sup>1</sup> / <sub>8</sub> (28.57)	1/4 X 1/8 (6.35 X 3.17)	2 <sup>5</sup> / <sub>8</sub> (66.67)	22 <sup>7</sup> / <sub>8</sub> (581.02)	10 <sup>1</sup> / <sub>2</sub> (266.7)	8 <sup>1</sup> / <sub>4</sub> (209.55)	12 <sup>1</sup> / <sub>4</sub> (311.15)	182T-326T	SP-2
3 X 4 X 10	4 (101.6)	3 (76.2)	31 <sup>3</sup> / <sub>4</sub> (806.45)	8 <sup>1</sup> / <sub>4</sub> (209.55)	14 <sup>1</sup> / <sub>4</sub> (361.95)	12 (304.8)	7 <sup>1</sup> / <sub>4</sub> (184.15)	12 <sup>1</sup> / <sub>2</sub> (317.5)	2 <sup>1</sup> / <sub>4</sub> (57.15)	1 <sup>1</sup> / <sub>8</sub> (28.57)	1/4 X 1/8 (6.35 X 3.17)	2 <sup>5</sup> / <sub>8</sub> (66.67)	22 <sup>7</sup> / <sub>8</sub> (581.02)	10 <sup>1</sup> / <sub>2</sub> (266.7)	8 <sup>1</sup> / <sub>4</sub> (209.55)	12 <sup>1</sup> / <sub>4</sub> (311.15)	182T-326T	SP-2
3 X 4 X 13	4 (101.6)	3 (76.2)	32 <sup>3</sup> / <sub>4</sub> (831.85)	10 (254)	17 (431.8)	16 (406.4)	7 <sup>1</sup> / <sub>4</sub> (184.15)	12 <sup>1</sup> / <sub>2</sub> (317.5)	1 <sup>1</sup> / <sub>4</sub> (31.75)	1 <sup>1</sup> / <sub>8</sub> (28.57)	1/4 X 1/8 (6.35 X 3.17)	2 <sup>5</sup> / <sub>8</sub> (66.67)	26 <sup>1</sup> / <sub>2</sub> (673.1)	11 <sup>1</sup> / <sub>2</sub> (292.1)	8 <sup>7</sup> / <sub>8</sub> (225.42)	13 <sup>1</sup> / <sub>4</sub> (336.55)	182T-326T	SP-2
4 X 6 X 13	6 (152.4)	4 (101.6)	33 <sup>3</sup> / <sub>4</sub> (857.25)	10 (254)	17 (431.8)	16 (406.4)	7 <sup>1</sup> / <sub>4</sub> (184.15)	12 <sup>1</sup> / <sub>2</sub> (317.5)	1/4 (6.35)	1 <sup>1</sup> / <sub>8</sub> (28.57)	1/4 X 1/8 (6.35 X 3.17)	2 <sup>5</sup> / <sub>8</sub> (66.67)	28 <sup>1</sup> / <sub>8</sub> (714.37)	13 (330.2)	9 (228.6)	14 <sup>1</sup> / <sub>4</sub> (361.95)	182T-326T	SP-2

DIMENSIONS SHOWN ARE IN INCHES AND (MILLIMETERS)

BASEPLATE	HA	HB	HE	HF	HG	HH
SP-1	15 (381)	50 (1270)	6 (152.4)	47 <sup>1</sup> / <sub>2</sub> (1206.5)	2 <sup>7</sup> / <sub>8</sub> (73.02)	3/4 (19.05)
SP-2	20 (508)	65 (1651)	8 <sup>1</sup> / <sub>2</sub> (215.9)	62 <sup>1</sup> / <sub>2</sub> (1587.5)	4 (101.6)	1 (25.4)

# ENGINEERING INFORMATION – SERIES 1600

PUMP IMPELLER DIAMETER X SUCTION X DISCHARGE		2 x 3 x 6	1 x 1.5 x 8	2 x 3 x 10	3 x 4 x 10	3 x 4 x 13	4 x 6 x 13	
CASING DATA	MAX. SPHERE SIZE	.500 (12.70)	.313 (7.95)	.375 (9.53)	.625 (15.90)	.500 (12.70)	1.000 (25.40)	
	IMPELLER CLEARANCE	FRONT	.015 (.38)	.020 (.51)	.025 (.64)			
		BACK	.045 (1.04)	.040 (1.02)	.035 (.89)			
	CASING THICKNESS (MIN)	.625 (15.90)		.750 (19.05)		1.000 (25.40)		
SHAFT AND BEARING DATA	DIA. AT IMPELLER	.750 (19.05)		1.250 (31.75)				
	DIA. UNDER SLEEVE	1.125 (28.60)		1.750 (44.45)				
	DIA. AT BEARINGS IB/OB	1.375/1.375 (35.00/35.00)		1.968/1.771 (50.00/45.00)				
	DIA. BETWEEN BEARINGS	1.625 (41.30)		2.250 (57.15)				
	BEARING SPAN	3.790 (96.30)		7.090 (180.10)				
	DIA. AT COUPLING	.875 (22.22)		1.125 (28.60)				
	BEARING NO. INBOARD	307MZC3		310MZC3				
	BEARING NO. OUTBOARD	5207AZC3		5309EZC3				
	MAX. SHAFT HP (KW) PER 100 RPM	1.14 (.85 KW)		4.00 (2.98 KW)				
	L-10 LIFE	MINIMUM 3 YEARS (26,280 HOURS)						
	L <sup>3</sup> /D <sup>4</sup> *	152		46				
	BEARING FRAME GROUP	I		II				
OIL CAPACITY, PINTS (ℓ)	.375 (.18ℓ)		2.000 (.95ℓ)					
BOX DATA	SLEEVE (O.D.)	1.375 (35.00)		2.125 (54.00)				
	STUFFING BOX BORE	2.000 (50.80)		2.875 (73.02)				
	MAX. DEPTH OF BOX	2.750 (69.85)		3.250 (82.55)				
	DISTANCE TO FIRST OBSTRUCTION	3.140 (79.76)		3.980 (101.10)				

DIMENSIONS SHOWN ARE IN INCHES AND (MILLIMETERS)

L<sup>3</sup>/D<sup>4</sup>\* – THE LOWER THE NUMBER, THE STIFFER THE SHAFT (AND THEREFORE LESS SHAFT DEFLECTION AND IMPROVED MECHANICAL SEAL LIFE).

## PRESSURE-TEMPERATURE RATINGS\*

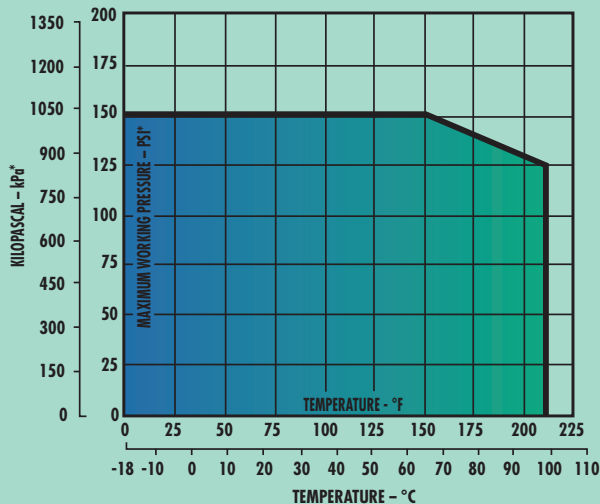

## SHAFT HORSEPOWER (KW) LIMITS

RPM	3500	2900	1750	1450	1150
Group I	40 HP (30 KW)	33 HP (25 KW)	20 HP (15 KW)	17 HP (12 KW)	13 HP (9.8 KW)
Group II	140 HP (104 KW)	115 HP (88 KW)	70 HP (52 KW)	58 HP (43 KW)	46 HP (34 KW)

\*Based on suction chamber pressure of 0 to full vacuum. Consult factory if positive suction pressures are to be encountered.

# OPTIONS DESIGNED TO ELIMINATE ALIGNMENT PROBLEMS

## C-FACE ADAPTER

- Available on all Fybroc Series 1600 Group I and Group II pumps
  - Group I – motor frame sizes up to 256TC
  - Group II – motor frame sizes up to 365TSC
- Designed to simplify pump/motor installation and alignment
- Reduces routine maintenance

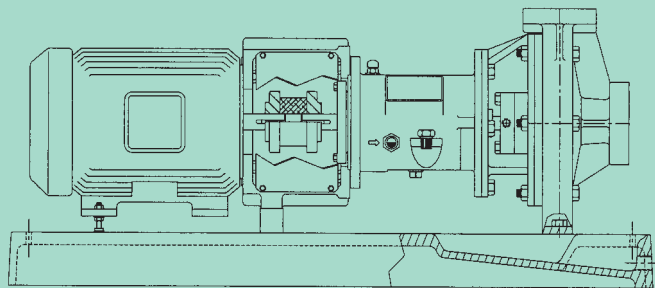
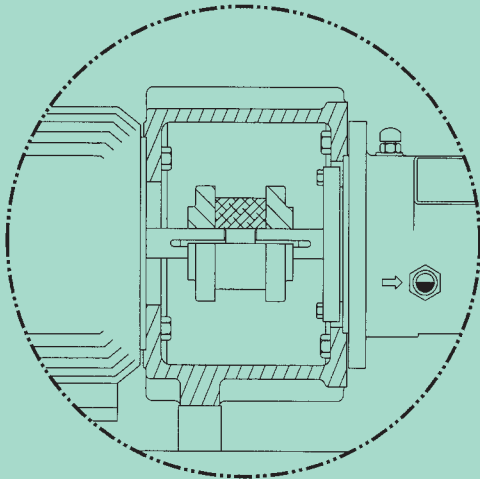

## CLOSE-COUPLED PUMPS

- Capacities to 1500 GPM (345 m<sup>3</sup>/hr)
- Heads to 325 Ft (99 m)
- C-faced JM extension motors up to 50 HP (37 KW)
- 6 sizes (all Fybroc Series 1600 Group I and Group II pumps)
- Available for mounting on FRP baseplates
- Lightweight/space efficient design
- Anti-spin-off device (segment key/locking ring) incorporated on the back end of the impeller sleeve to help protect against potential reverse rotation damage.



## FYBROC SERIES 2630 SELF-PRIMING

- Capacities to 300 GPM (70 m<sup>3</sup>/hr)
- Heads to 200 feet (65 m)
- Suction Lifts to 20 feet (6 m)
- Two pump sizes



The Fybroc Series 2630 is an FRP, close-coupled, self-priming, magnetic-drive sealless pump that incorporates many of the features found on the Fybroc Series 2530 pumps. With the exception of the casing volute/tank assembly, all components of the Series 2630 are fully interchangeable with those of the Series 2530. The Series 2630 is ideally suited for corrosive sump applications, tank car unloading, and other similar, demanding applications. The volute casing has been designed with optimal proportions in the recirculation chamber to provide for short and efficient priming times, without the use of troublesome check valves. The volute casing inlet has also been designed to minimize NPSH requirements, thereby leading to greater allowable suction lifts.

An important feature of the Series 2630 is its replaceable volute extension. The casing volute cutwater in any self-priming pump must be in close proximity to the impeller in order to permit efficient priming. The removable volute extension in the Series 2630 is available in a number of sizes to match specific impeller diameters permitting field hydraulic changes and the restoration of priming efficiency, all without casing modifications or replacement.



### Fybroc Division

700 Emlen Way, Telford, PA 18969

TOLL-FREE: 1-800-FYBROC-1, Phone: (215) 723-8155, FAX: (215) 723-2197

E-Mail: [sales@fybroc.com](mailto:sales@fybroc.com), Web Site: [www.fybroc.com](http://www.fybroc.com)



AMERICAN ZOO AND AQUARIUM ASSOCIATION

